

FACTORY AUTOMATION



www.seec.com.tw

Shihlin Brand

PLC	AX 0N / AX 1S / AX 1N / AX 2N
INV	SV / SH / SE series
	SS / SL / RC series
HMI	EU series
Temperature Controller	WT/SD series
DVR	PH / PM series

Agency Brand

SUNX	Sensor and Laser Marker
SANKEN	Inverter
Mitsubishi	PLC / HMI / INV / Servo
Cognex	Checker
CKD	Pneumatic Cylinder
Aiphone	Intercom

HEAD OFFICE 16F, No.88, Section 6, ChungShan N. Road, Taipei, Taiwan 111 TEL:(02)2834-2662
Automation Business group sales head Dept.

No.234, ChungLun, HsinFeng, HsinChu, Taiwan 304 TEL:(03)599-5111

Branches Around Taiwan

Taipei Branch	3F, No.9, Section 1, ChangAn Road, Taipei, Taiwan 104	TEL:(02)2541-9822
Hsin Chu Branch	No.23, Chung-Hwa Rd., HukoHsiang, HsinChu, Taiwan 303	TEL:(03)590-5200
TaiChung Branch	No.134-3, Section 3, ChungGun Road, TaiChung, Taiwan 407	TEL:(04)2461-0466
TaiNan Branch	No.198, Section 1, ChungHwa E. Road, TaiNan, Taiwan 701	TEL:(06)201-8979
KaoShung Branch	No.250, ChungHwa 2nd Road, SunMing District, KaoShung, Taiwan 807	TEL:(07)316-0228



Micro computer
temperature controller

SD series

WT series



FACTORY
AUTOMATION

SD series



Anit-traditional 、 Module Streamline style 、 Super-Miniature

- DIN RAIL, magnetic seat, screw, 3 installation ways, Flexibly match the requests of outside panel board for Panel Board.
- High reliability Modbus communication, Easily connect with HMI and PLC.
- Supply free charge of monitoring software, it is very convenient for short distance operation to remote control and parameter copy.
- Small volume, multi pieces assembly side by side, composed of multi points and circuit controllers instead of single loop and point control.
- Directly use and correspond to universal voltage AC100~240V without connecting external DC power and can save the cost.

SDV High Performance Type.

- Plug in out terminal design is easy connection.
- External control box with double display has 7 segments display itself and can show PV value.
- New LED module design with 4 big digit display of PV and SV in control box is touched smoothly and can be plug in out and operate easily.
- The controller can be independently operated when the external control box is plug out from the controller after parameter setting to prevent the man-made operating mistake.

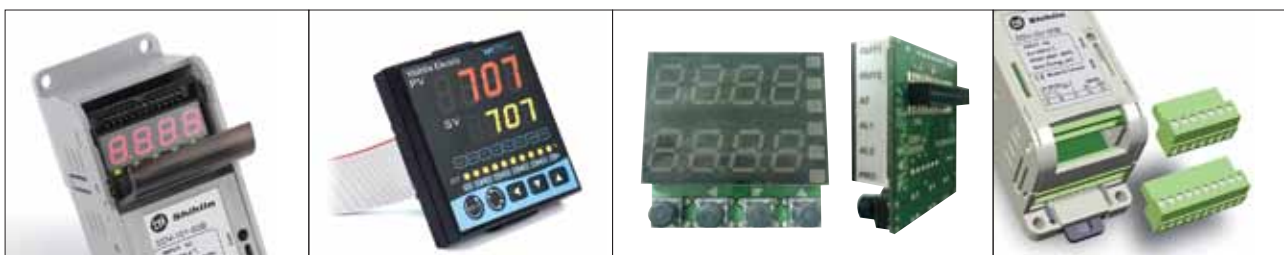

External control box

Double display
Type: WTPU
Size: 72*72*15 mm

Double display
Type: WTPUS
Size: 35*35*14mm

Plug-in-out terminal

SDE Economic Type

- Reasonable prices, high reliability, replace traditional controllers, which should be need to hole to assemble.
- Single display design and keyboard operation directly.
- Down lift transparent cover design, avoid mistaking touch and operation.



Build in 4 keys and single display



Fixed terminal

Multi-Option of Inputs and Outputs

- Completely correspond to any kinds of input signal like Thermo Couple, RTD PT100, and DC4~20ma, 0~5V, etc.
- Satisfy any requests for output mode like DC4~20mA, 0~5V voltage, current and the relay output of capacity 8A.
- Provides with 3 features of controller, signal converter and alarm monitor, It can change the signal of mV, V, RTD to the output of voltage and current 4~20mA instead of the signal converter.
- Separately design for signal circuit and power circuit on PC board, effectively restrain the external interference of electric wave.

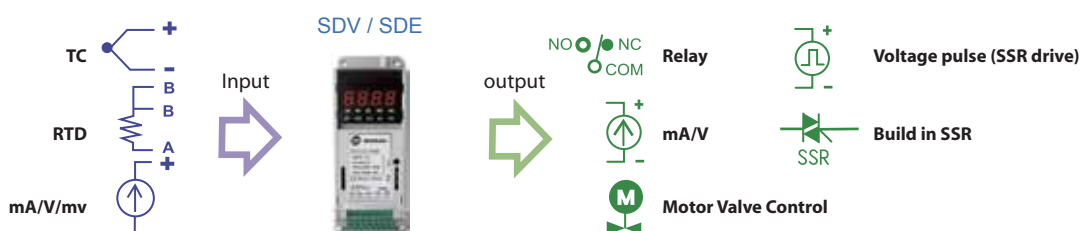

New-brand configuration design

DIN RAIL Installation

- Provided with two installing ways of DIN RAIL and Screw Lock, and suit for a considerable quantities installation in the panel board, it is easy to install and take out controller itself.



5 LED Indicator Lights

- LED shows alarm, control, output. Watch the acts condition clearly.



Design of Separating Secure Cover for Terminal

- Brand-new design of secure covers for terminal with European standard.
- Terminal with power doesn't expose external and feel artistic and security.



Compact Module Assembly Design

- Organization assembly disassembles easily, extreme light.
- Provided the advance SMT manufacturing system, high quality and high reliability.



Base Attaches the Magnetic Place (Use for SDV)

- Base attaches 3 magnets, it may adsorb the made of iron box body willfully.
- Don't need to worry about fix it problem, suitable in the short period testing or gauging.

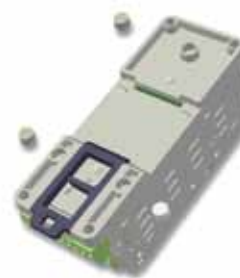

Interval Spacer Design

Controllers can be installing side by side through using the attached round interval stick to keep a distance between controllers to increase and assure the efficiency of heat release and control if there are some heating equipments ofr the using ambient temperature is higher.



Plug in the round interval stick on the up half of both sides are available.



Do not plug in the round interval spacer on the down half of both side, avoid the efficiency of compensating for normal temperature.

HBA- Heater Break Alarm

- Corresponding to the function of HBA under 100A, Two CT of 80A and 100A are available.
- Current rated range: 0.0~99.9A, Accuracy; 1% FS, Alarm terminal: AL1
- Attached accessory CT; SC-80-T (holing diameter; 5.8mm, 0.0~50.0A) or SC-100-T (Holing diameter: 12mm, 0.0~99.9A)

CT 80A

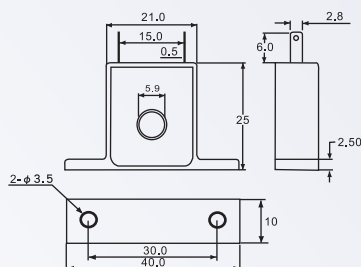

CT 100A

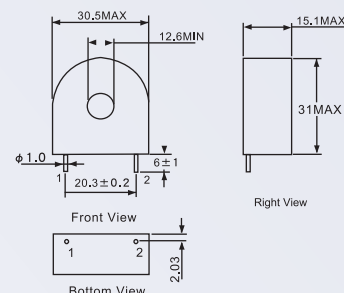

Ultra intrepid. Option function

Transmission

FA controllers can use the function to transmit the PV or SV value to external device.

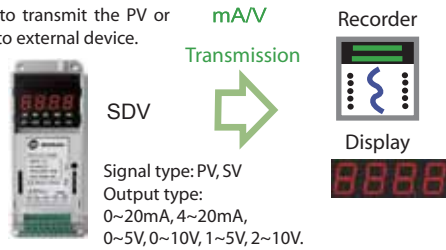

Remote SV

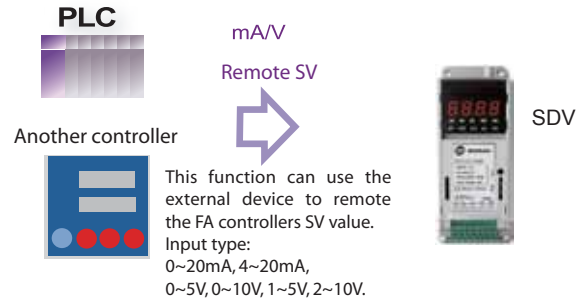

Motor Value Control

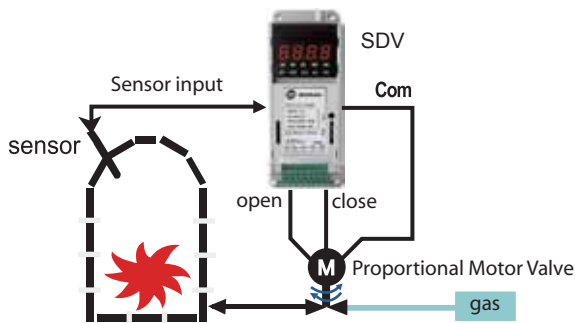

Ramp/Soak Program

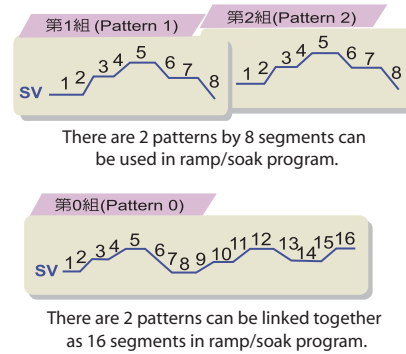

Big Capacity Terminal Design

Relay: SPST terminal with 8A ;
SPDT terminal with 3A



SSR High life relay:

Build in an additional high life of relay (1A SSR), which is without terminal consumption, and suit for high frequency operation.



Maximum Expanded

1 output 2 alarm or 2 output 1 alarm

Alarm types

Alarm types list as below:

Deviation:

Deviation High alarm
Deviation Low alarm
Deviation High
Low alarm/Band alarm

Program:

Program Run alarm
Program END alarm
Segment End alarm

PV:

PV High alarm
PV low alarm

System:

System Failed alarm
System Normal alarm.
Heater break alarm

Assembly

When assembling plug in SDV on DIN RAIL and then lodge the bottom in easily.



When taking out of SDV, insert into the square hole on the bottom of SDV with driver and put front and then it can be taken out from DIN RAIL.

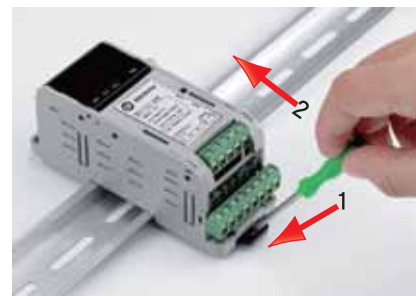

Parameter Copy Function by USB Interface

- Using USB converter(SDU01) to communicate with PC, the data of master controller can be copied to another FA type controller, It can be saved a lot of time and avoid the parameter key-in mistake.
- SDU01 USB communication converter uses DC5V power from computer. It can still copy the parameter even the controller without the power.



SDU01 Universal converter USB ↔ RS-485/RS-422/RS-232/TTL

- SDU01**
- It is suitable for various of industrial equipments such as PLC, HMI, Inverters, Temperature controllers provided the communicated interface like; RS-485/RS-422/RSS-232 and TTL to communicate and control with computer.
 - It provided 3 kind of converting connectors and 3 kind of cables which are available for changing and extending use.



Super Communication function of MODBUS (RTU, ASCII)

- It can be connected and controlled with any FA products which owned the communicated interface of MODBUS.
- Easily connect HMI \ PLC or connect PC monitor system.
- To select the monitor mode by hour or day through MODBUS RS-485 communication software which Shihlin Supplied with free charge.
- All data can be saved in TXT or EXECL file.
- All the saved data can be retrieved to use, and can be made as a reference of historical trend diagram.

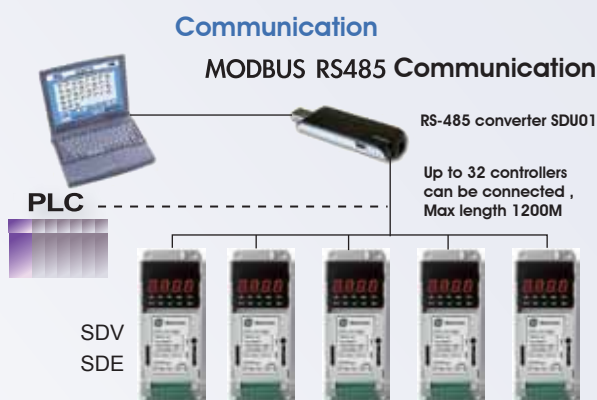

Historical trend diagram

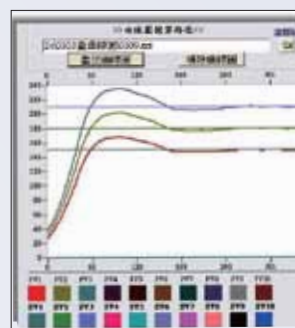

Terminal Wiring Diagram.

SDV High performance type Plug-in-out Pitch 3.5mm

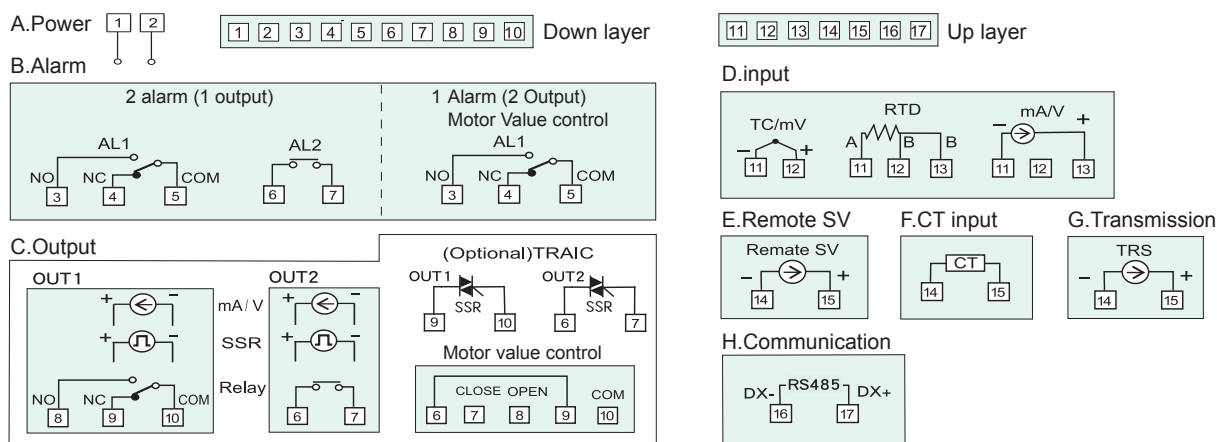

SDE Economic Type Fixed Pitch 5.0mm

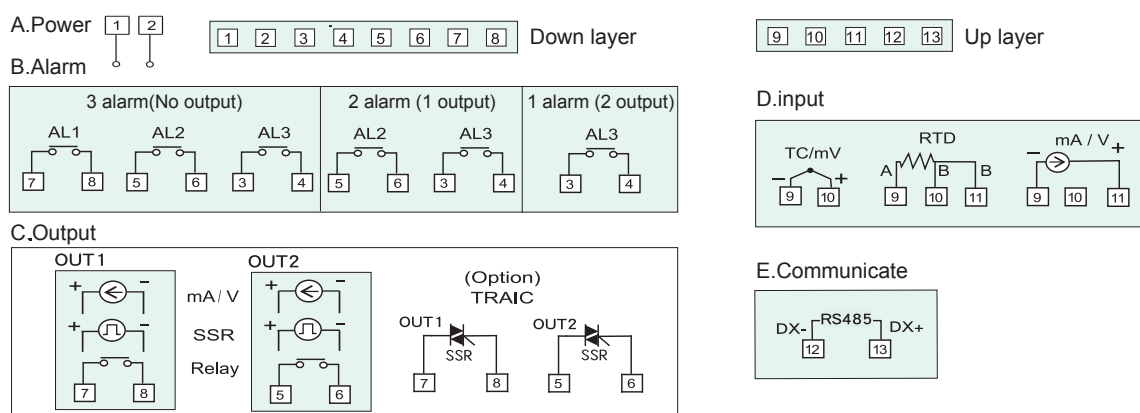

Dimension

Front drawing

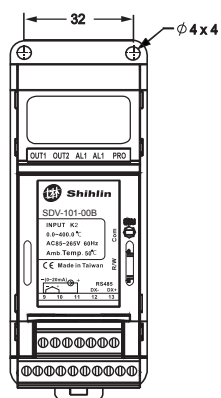

back drawing

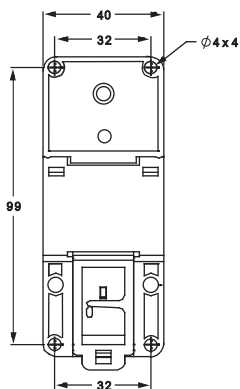

side drawing

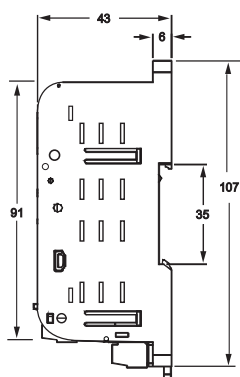

DIN RAIL dimension (reference)

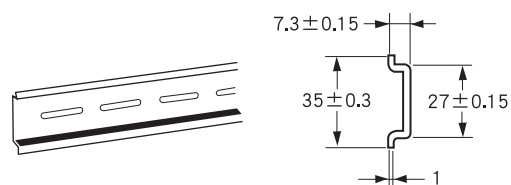

Standard Spec.

Standard Spec.

Model		High performance type SDV	Economic Type SDE
Wiring terminal		Plug in out terminal	fixed terminal
Parameter setting		by external control box or by communication	build in 4 operating keys or by
Assembly		Din rail, M4 screw hole, magnetic seat	Din rail or M4 screw hole
Display		External control box with double display+ PV single display	single display
Standard accessories		1 output + 1 Alarm	
Maximum expansibility		1 Output + 2 Alarms or 2 Outputs +1 Alarm	
additional option	Programmable 2 patterns by 8 segments	Yes (option)	Yes (option)
	High life SSR	Yes (option)	Yes (option)
	Communication	Yes (option)	Yes (option)
	Motor Valve Control	Yes (option)	NO
	TRS	Yes (option)	NO
	Remote SV	Yes (option)	NO
	Heater Break Alarm(HBA)	Yes (option)	NO

General Spec.

Supply Voltage	AC85-265V	
Frequency	50/60HZ	
Power Consumption	Approx 4VA	
Data protection	EEPROM, ndurance: 1 Million write cycles, Data Retention: 10 years	
Isolated resistance	Main loop-case(ground), control loop-case (ground) DC500V>10M Ω	
Dielectric Strength	Main loop-case(ground) AC 1500V 1min / control loop-case(ground) AC 1000V 1min	
Vibration Endurance	10~55HZ 0.5mm (MAX 2G) XYZ various direction 2h	
Assault Endurance	100m/s2 (Approx 10G) XYZ various direction 3 times	
Protecton configuration	IP 00	
Display height of control box	LED Module PV: 14mm SV:10mm	without control box
Display height of single range LED	7 section digital display: 7mm	
Dimension	40x107x43mm	
Weight	115g	
Operating Ambient temperature	0~50 $^{\circ}$ C	
Operating Ambient temperature	correspondent humidity 20~90% RH without dew	
Reseved temperature	-25 $^{\circ}$ C ~ +65 $^{\circ}$ C	

Control Features

Control method	Heating, cooling single output or heating and Cooling both output PID, PI, PD, P,
PID Parameter	P: 0.0~200.0%
	I: 0~3600sec.
	D: 0~900 sec.
Control cycle	0~150秒

Input Features

Input	The point of signal point	one point
	Accuracy	0.2% Full Scale \pm 1digit
	Sample time	250 ms
	TC	K, J, R, S, B, E, N, T, W5Re, W26Re, PLII, U, L
	RTD	PT100, JPT100
	mA(DC)	4-20mA, 0-20mA
	Voltage(DC)	0-1V, 0-5V, 0-10V, 1-5V, 2-10V, 10-10mV, 0-10mV, 0-20mV, 0-50mV, 10-50mV
	DP position option	When using the input of sensor signal, DP position for PV can be selected the sensor code When using the input of DC mA or Voltage, DP position for PV can be selected code No.
	0000 000.0 00.00 0.000	

Communications

Interface	RS-485 two wries Half Duplex
Protocol	Modbus RUT, Modbus ASCII, TAIE
Data bit	8 bit
Start bit	1 bit
Stop bit	1 bit or 2 bit
Baud rate	38400、19200、9600、4800、2400、1200、300、110bps
Error examine	Parity even, odd or CRC-16 (in Modbus)
Connective pieces	Maximum 32pcs
Communicate range	Maximum 1200m

Output Features

Input1	Relay	SPDT typ(a point 8A, b point 3A 220V)	SPST type (1a point 8A 220V)
	for external SSR drive	ON : 24V, OFF : 0V, Max. load current 20mA	
	4-20mA / 0-20mA	Max, load resistance 560 Ω	
	0-5V, 0-10 V	Max, load current 20mA	
	SSR high life relay	1A TRIAC SSR (Option)	
Input2	Relay	SPST type 8A 220V	
	for external SSR drive	ON : 24V, OFF : 0V, Max. load current 20mA	
	4-20mA / 0-20mA	Max, load resistance 560 Ω	
	0-5V, 0-10 V	Max, load current 20mA	
	SSR high life relay	1A TRIAC SSR (Option)	

Alarms

Alarm 1 realy	SPDT type (a point 8A, b point 3A 220V)	SPST type 1a point 8A 220V
Alarm 2 realy	SpPST type 8A 220V	
Alarm setting range	-9999~9999 (Dot positions are different depended on the various input types)	

WTseries Win Temperature

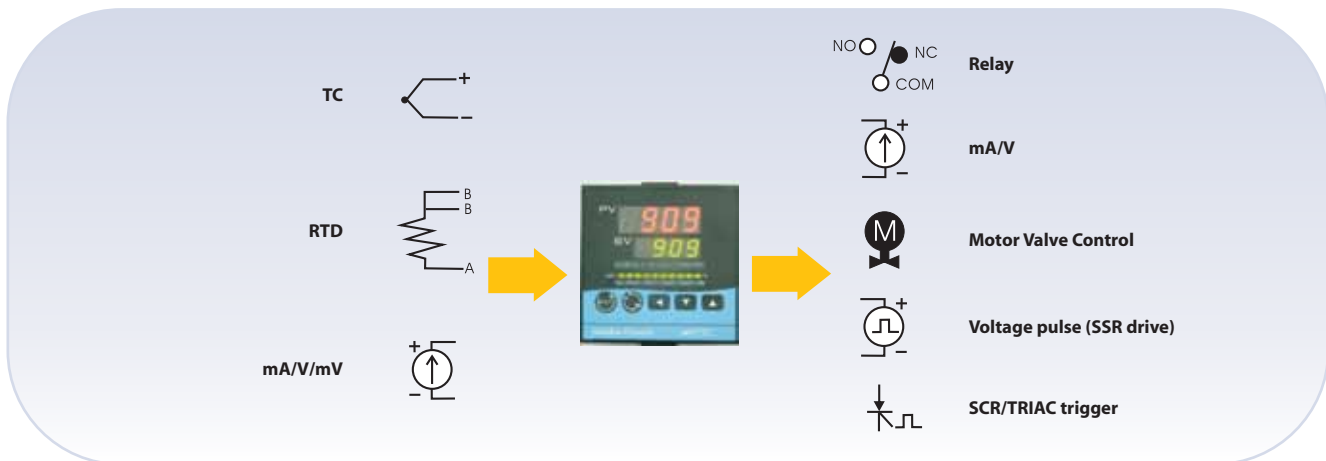

Excellent Control

Multiple Inputs and Signals. It is high quality and reliable.

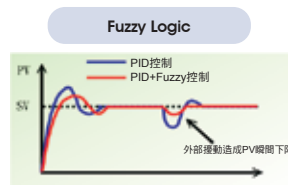
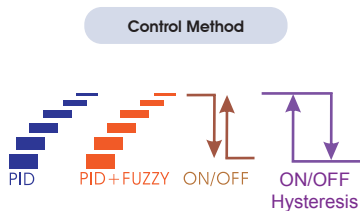

Built in Fuzzy logic suppress the overshoot due to SV changes or external disturbance.

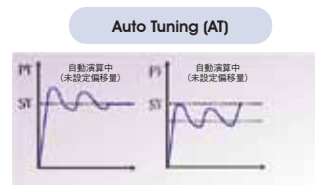

When Auto tuning is working, controller will make PV hunting 1~2 cycles to calculate optimize PID value, To protect user's device, WT series controller can perform PV hunting below SV by setting AT bias value (ATVL).

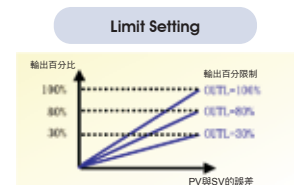

Build in output limit function. Using this function to get different gradient output and set limit for output.

Special Application

Ramp/Soak Program

Pattern 1 Pattern 2



There are two patterns by 8 segments can be used in ramp/soak program.

Pattern 0



There are two patterns can be linked together as 16 segments in ramp/soak program.

Motor Value Control

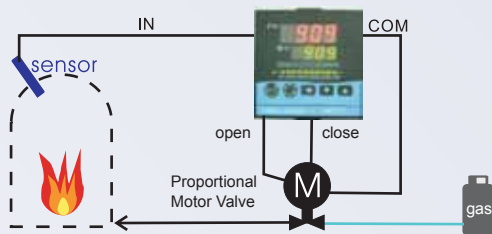

Heating and Cooling Control

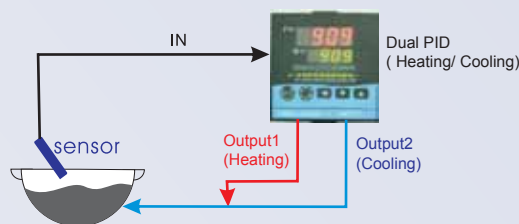

SCR/ TRIAC trigger

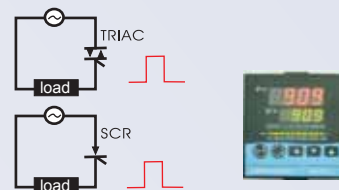

1Ø/3Ø Zero Cross control(1Ø/3Ø SSR)
1Ø/3Ø Phase Angle control(1Ø/3Ø SSR)

Ultra intrepid. Option function

Remote SV

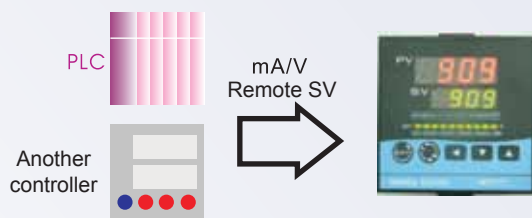

The function can use the external device to remote the FA controller SV value.
Input type:0~20mA, 4-20mV,0~5V,0-10V,1-5V,2-10V

Communication

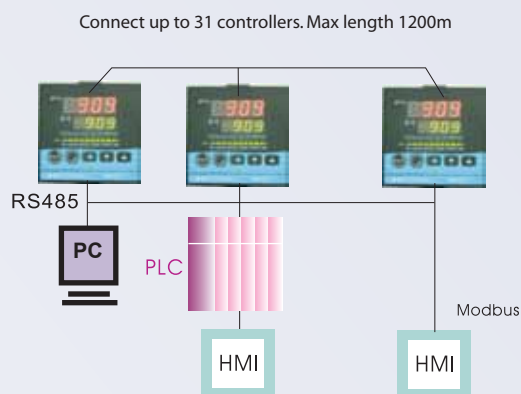

TTL communication
Connect up to 10 controllers. Max length 1M
The SV value of slave controllers will be remote master controller, and reached to max value at the same time.

Transmission

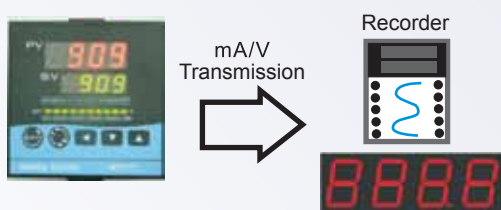

FA controllers can use this function to transmit the PV or SV value to external device.
Signal type: PV,SV
Output type: 0~20mA, 4-20mV,0~5V,0-10V,1-5V,2-10V

Easy Installation

Easy Mounting

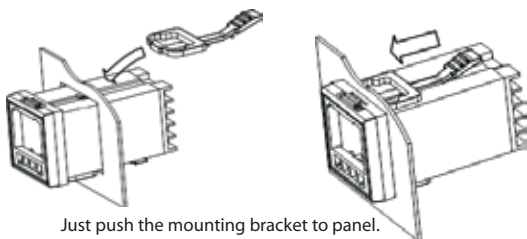

Just push the mounting bracket to panel.
Without using any screws.

Saving Space

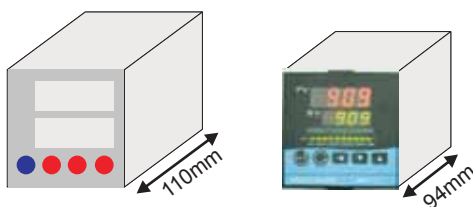

Just push the mounting bracket to panel.
Without using any screws.

Alarm Function

Alarm Function

Maximum with 3 sets of alarm. Alarm types list as below.

- Deviation High Alarm
- Deviation Low Alarm
- Deviation High/Low Alarm
- Band Alarm

- System Failed Alarm
- System Normal Alarm
- Heater Break Alarm

- PV High Alarm
- PV Low Alarm

- Program Run Alarm
- Program End Alarm
- Segment End Alarm

Delay Time

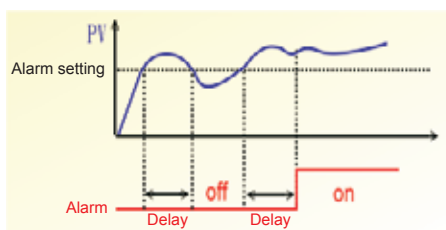

Using this function can avoid alarm acts frequently or acts due to external disturbance.

External Dimension

WT 404			
WT 904			
WT 707			
WT 409			
WT 909			

Parts Description

Out 1 % Bar-Graph display
 Best Output percent displayed on the bar-graph in 10 LEDs resolution (Except WT404)

Set Key

Auto/Manual Key
 Best Switches between Auto(PID) output mode and Manual output (Except WT404)

Up Key *Program Run

Down Key *Program Hold

Shift Key

Measured value (PV) display

Setting value (SV) display
 Best You can control every situations just in time

OUT1 OUT1 Lamp

OUT2 OUT2 Lamp

AT Autotuning Lamp

AL1 Alarm 1 Lamp

AL2 Alarm 2 Lamp

AL3 Alarm 3 Lamp

MAN Manual Output Lamp

PRO Program Running Lamp

Autotuning (AT)

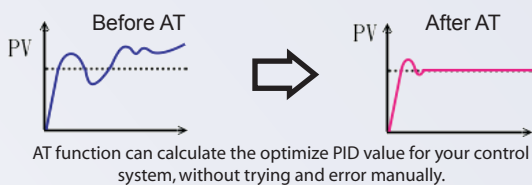

RAMP and Soak



Build in 1 segment of RAMP and SOAK function. Applicable on SOFT start condition.

IP 65 Proof



IP65 dust and water proof is available for all WT models.
 (* Option Function)

Approval and Free Power

All WT models get CE approval. Operate on any voltage from AC 85~265V at 50/60Hz. DC24V is also available (*Optional Function)

High Accuracy

Input with 14 bit A/D resolution, 0.2% accuracy of FS. Build in Auto Zero- Auto Span function to keep good accuracy.

Data Lock Function

All parameters are separated in 3 operation levels. Each parameter can be hidden or locked to prevent unauthorized changes.

Modbus Communication

WT series sport both Modbus RTU and MODBUS ASCII protocol. Communication between controller and HMI or other equipment is more convenient. (*Option Function)

Heater Break Alarm (HBA)

Heater current flowing through CT can be displayed on controller. If heater current is less than HBA set value, LA1 will be activated (*Optional Function)

Standar Spec

model	WT-404	WT-904	WT-707	WT-409	WT-909
Dimension	48x48mm	96x48mm	72x72mm	48x96mm	96x96mm
Supply voltage	AC 85-265V , DC24V(option)				
Frequency	50/60Hz				
Power Consumption	approximately 3VA	approximately 4VA	approximately 3VA	approximately 4VA	approximately 4VA
Memory	Non-volatile E ² RPOM				
input	Measurement input, Sample time:250ms				
TC	K, J, R, S, B, E, N, T, W, PL2, U, L,				
PID	PT100, JPT100, JPT50				
mA dc	4-20mA, 0-20mA				
Voltage dc	0-1V, 0-5V, 0-10V, 1-5V, 2-10V, -10-10mV, 0-10mV, 0-20mV, 2-50mV, 10-50mV				
DP P position	0000, 000.0, 00.00, 0.000 (available for mA or Voltage dc input)				
Output	Main control output (HEAT mode or COOL mode)				
Relay	SPST type	SPDT type	SPDT type	SPDT type	SPDT type
	3A, 220V, electrical life : 100,000 time or more(under the rated load).				
Voltage Pulse	For SSR drive. ON:24V, OFF:0V, maximum load current :20mA.				
mA dc	4-20mA, 0-20mA, maximum load resistance:560Ω				
Voltage dc	0-5V, 0-1V, 1-5V, 2-10V, maximum load current:20mA				
Alarm1	SPST type	SPDT type	SPST type	SPDT type	SPDT type
	3A, 220V: electrical life: 100,000 times or more (under the rated load)				
Control algorithms	PID, P, PI, PD, ON/OFF(P=0), FUZZY				
PID range	P:0-200%, I:0-3600 Secs, D:0-900 Secs				
Accruacy	0.2% of FS				
Isolation	Output terminal (control output, alarm, transmission) and input terminal are isolated separately				
Isolated resistance	10MΩ or more between input terminals and case(ground)at DC500V / 10MΩ or more between output terminals and case(ground)at DC500V				
Dielectric strength	1000V AC for 1 minute between input terminals and case (ground) / 1500V AC for 1 minute between output terminals and case (ground)				
Operating temperature	0-50°C				
Humidity range	50-85% RH				
Weigh	WT404 approx150g, WT407/WT704/WT707 approx 225g, WT909 approx 300g				
Display Height	PV:7mm/SV:14mm	PV:7mm/SV:7mm	PV:14mm/SV:10mm	PV:7mm/SV:7mm	PV:14mm/SV:10mm

Optional Spec.

Mode	WT-404	WT-904	WT-707	WT-409	WT-909
RAMP/SOAK P rogram	2 Patterns with 8 segments each. The 2 patterns can be linked together as 16 segments use.				
Output 2	For heating and cooling control use.				
Relay	SPST type	SPST type	SPST type	SPST type	SPST type
Voltage Pulse	For SSR drive.ON:24V, OFF:0V, maximum load current:20mA				
mA dc	4-20mA, 0-20mA, maximum load resistance:560Ω				
Voltage dc	0-5V, 0-1V, 1-5V, 2-10V, Maximum load current:20mA.				
Alarm 2	SPST type	SPDT type	SPDT type	SPDT type	SPDT type
Alarm 3	X	SPST type	SPST type	SPST type	SPST type
Heater Break Alarm(HBA)	Display Range of Heater Current :0.0~99.9A, Accuracy :1%FS Included CT: SC-80-T(5.8mm dia, 0.0~80.0A) or SC-100-T (12mmdia, 0.0~99.9A) Alarm Relay : AL1				
Transmission	Available for PV or SV transmission				
mA dc	4-20mA, 0-20mA, maximum load resistance:560Ω				
Voltage dc	0-5V, 0-1V, 1-5V, 2-10V, maximum load current:20mA				
Remote SV Input	4~20mA, 0~20mA, 0~5V, 0~10V, 1~5V, 2~10V are available				
Communication	Protocol:MODBUS, RS232, RS485, TTL				
	Interface:RS232, RS485, TTL				
	Baudrate:38400,19200,9600,4800,2400 bps				
Water Proof/Dust Proof	Data bit:8,Start bit:1,Stop bit:1or2,Odd or Even parity				
	IP65				

Terminal Arrangement

WT 404

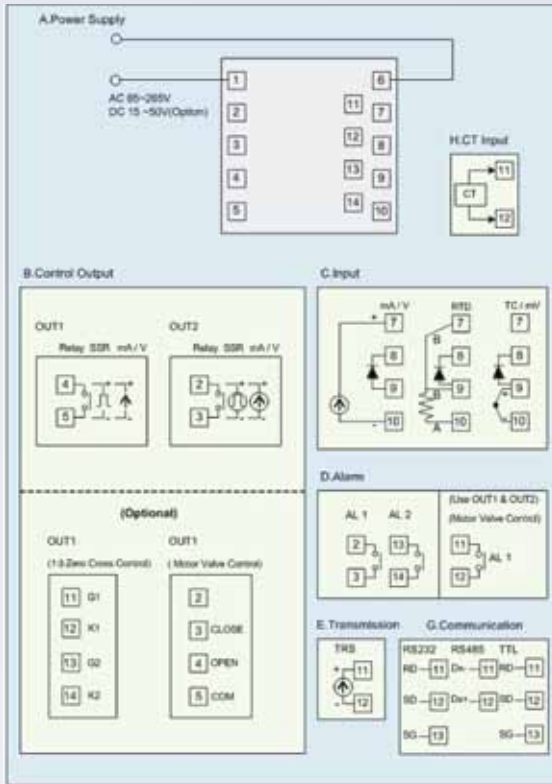

WT 707

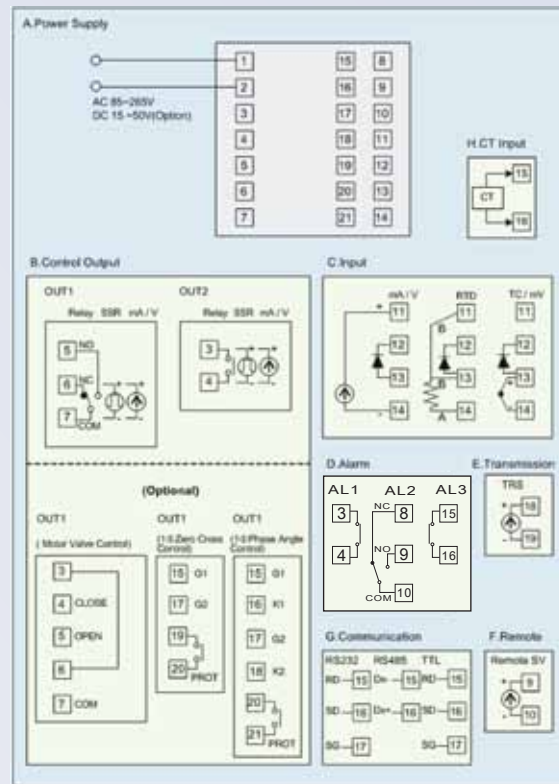

WT 409 904

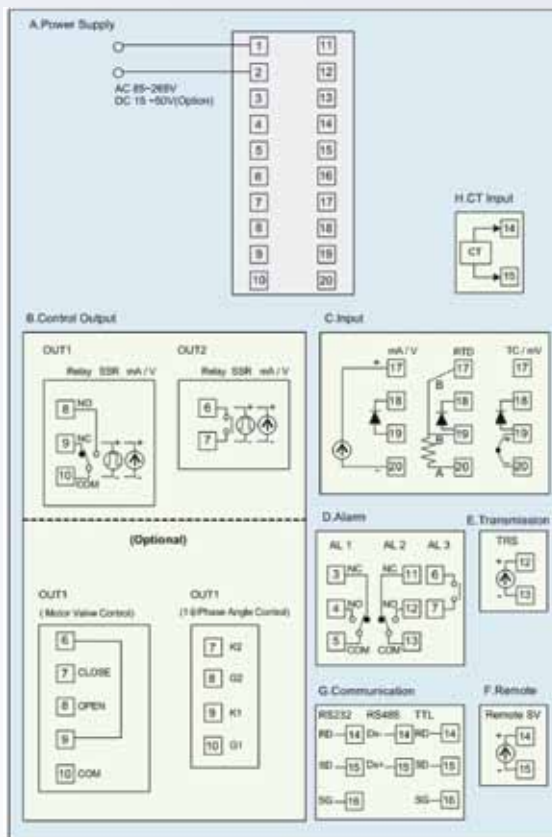

WT 909

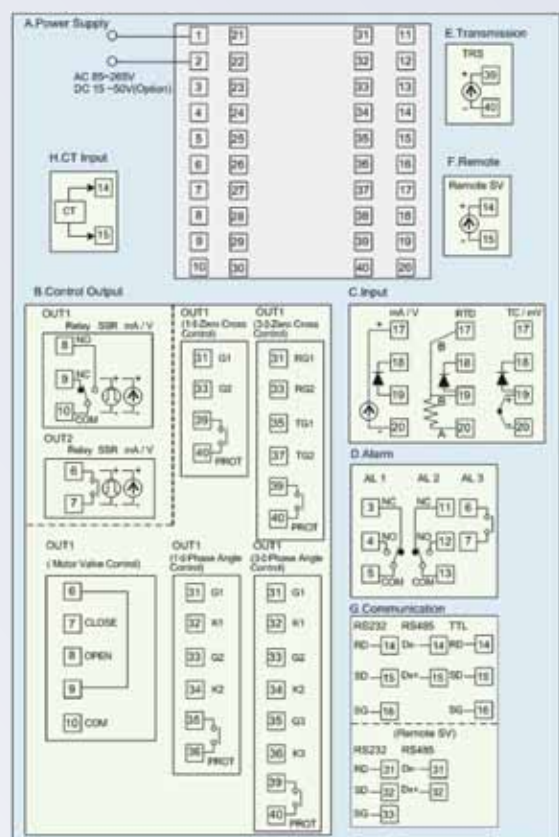

Order Information

Order sample

Model	output1	output2	Alarm	Transmission	Remote SV	Communication	Input type	Power	Programmable
WT404	1	0	1	0	0	B	02	A	S
WTSDV	1	0	2	0	0	B	02	A	S

Order information

Model	output1		output2		Alarm		Transmission		Remote SV		Communication		Input type	Power	Programmable	
WT404	0	None	0	None	0	None	0	None	0	None	0	None	02	A	S	Standard
WT707	1	Relay	1	Relay	1	one	1	4~20mA	1	4~20mA	A	RS232-MODBUS	ee Input Codes	AC 85-265V	P	Programmable
WT409	2	Voltage Pulse (SSR Drive)	2	Voltage Pulse (SSR Drive)	2	two	2	0~20mA	2	0~20mA	B	RS485-MODBUS		DC 15-50V		
WT904	3	4~20mA	3	4~20mA	3	three	A	0~5V	A	0~5V	3	TTL				
WT909	4	0~20mA	4	0~20mA	A	HBA	B	0~10V	B	0~10V						
WTSDV	High performance type		A	0~5V	A	0~5V	B	HBA+AL2	C	1~5V	C	1~5V				
WTSDV	Economic type		B	0~10V	B	0~10V	C	HBA+AL2+AL3	D	2~10V	D	2~10V				
			C	1~5V	C	1~5V										
			D	2~10V	D	2~10V										
			5	1 § SSR	T	TRIAC(SSR)										
			6	3 § SSR												
			8	1 § SCR												
			9	3 § SCR												
			T	TRIAC(SSR)												
			7	Motor value control												

Above black blocks line are standard functions.
Yellow blocks are optional functions with SDV and SDE
Red blocks line are optional functions with WT series

O : Option X: No option
Maximum expand is 1 output 2 alarms or 2outputs 1 alarm
HBA and Remote function can not be selected at the same time.

Combination of options and models

Model	Program	output1					output2	Alarm2	Alarm3	HBA	Transmission	Remote SV	Communication	Power DC24V
		1 § SSR	3 § SSR	Motor valve control	1 § SCR	3 § SCR								
WT404	o	o	x	o	x	x	o	o	x	o	o	o	o	o
WT707	o	o	x	o	o	x	o	o	o	o	o	o	o	o
WT409	o	x	x	o	o	x	o	o	o	o	o	o	o	o
WT904	o	x	x	o	o	x	o	o	o	o	o	o	o	o
WT909	o	o	o	o	o	o	o	o	o	o	o	o	o	o
WTSDV	High performance type	o	x	x	o	x	x	o	o	x	o	o	o	x
WTSDV	Economic type	o	x	x	x	x	x	o	o	x	x	x	o	x

* SDV and SDE can option TRIAC SSR function in output1

Input type

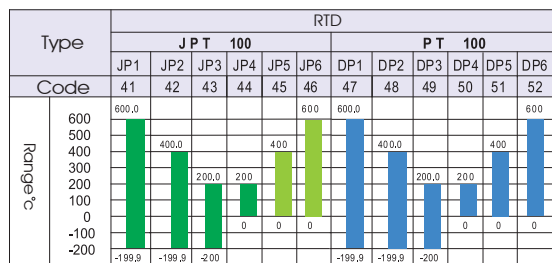
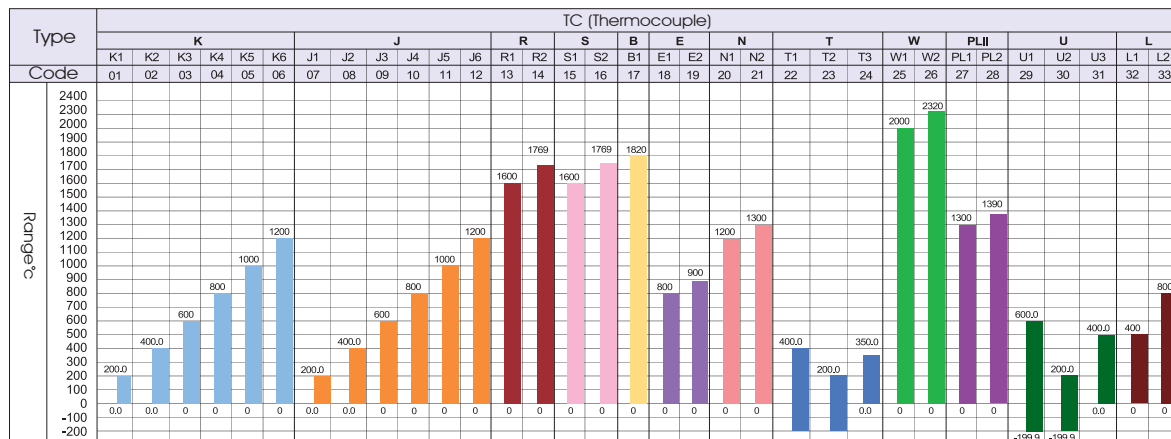

Type	Linear																
	AN1			AN2		AN3			AN4				AN5				
Code	61	62	63	64	71	76	81	82	83	84	85	86	87	91	92	93	94
input range	-10~10mV	-2~2V	-5~5V	-10~10V	0~10mV	0~20mV	0~50mV	0~20mA	0~1V	0~5V	0~10V	0~5KΩ	0~2V	10~50mV	4~20mA	1~5V	2~10V
Set range	Four kinds of choices -1999~9999 -199.9~999.9 -19.99~99.99 -1.999~9.999																